

# Instruction Manual

**Basic Line Torque  
Sensor  
Type 4520A...**

CE

# KISTLER

measure. analyze. innovate.



## Instruction Manual

**Basic Line Torque  
Sensor  
Type 4520A...**

CE



## Foreword

This manual applies to the Basic Line Torque Sensor Type 4520A... .

The instruction manual must be kept on hand for future use, and must be available at the site of implementation of the NC joining system, as needed.

The specifications in this manual can change at any time without prior notification. Kistler reserves the right to improve and to change the product for the purpose of technical progress without the obligation to inform persons and organizations as the result of such changes.

Original language of these operating instructions: German

© 2009 ... 2014 Kistler Group. All rights reserved.

Kistler Group  
Eulachstrasse 22  
8408 Winterthur  
Switzerland  
Phone +41 52-224 11 11  
Fax +41 52-224 14 14  
info@kistler.com  
www.kistler.com

Product Center  
Torque Sensors, NC Joining Systems,  
Force-Displacement Monitoring, Test Stand Systems

Kistler Lorch GmbH  
Maierhofstrasse 35  
73547 Lorch  
Germany  
Phone +49 7172-184 0  
Fax +49 7172-184 400  
info.klr@kistler.com  
www.kistler.com

## Content

<b>1.</b>	<b>Introduction .....</b>	<b>3</b>
<b>2.</b>	<b>Important Information.....</b>	<b>4</b>
2.1	Disposal Instructions for Electrical and Electronic Equipment .....	4
<b>3.</b>	<b>Application and Key Features.....</b>	<b>5</b>
<b>4.</b>	<b>Description of the Measuring System .....</b>	<b>6</b>
4.1	Mechanical Design .....	6
4.2	Electrical Block Diagram .....	7
4.2.1	Examples of Application .....	8
4.3	Electrical Configuration of Speed Measurement .....	9
<b>5.</b>	<b>Electrical Connections of the Sensor .....</b>	<b>10</b>
5.1	Plug Connection.....	11
5.1.1	Installing the Signal Lead .....	11
5.2	Instruction for Electrical Installation .....	12
5.3	Connection Cables .....	13
5.4	Mechanical Installation of the Torque Sensor .....	14
5.5	Possible Installation Type 4520A... ..	15
<b>6.</b>	<b>Mechanical Application and Mechanical Installation of the Torque Sensor Type 4520A.....</b>	<b>16</b>
6.1	Frictional Torque Control in Production .....	16
6.2	Torque Measuring Shaft Version RA.....	17
6.3	Supply and Evaluation .....	18
<b>7.</b>	<b>Static Calibration.....</b>	<b>19</b>
7.1	Construction of a Simple Calibration Device .....	19
7.2	Calculation Example for Lever Arm Length.....	20
<b>8.</b>	<b>Maintenance .....</b>	<b>21</b>
<b>9.</b>	<b>Repairs .....</b>	<b>22</b>
<b>10.</b>	<b>Declaration of Conformity .....</b>	<b>23</b>
<b>11.</b>	<b>Accessories and Ordering Key .....</b>	<b>24</b>
<b>12.</b>	<b>Index .....</b>	<b>25</b>

Total Pages 25

## 1. Introduction

Please take the time to thoroughly read this instruction manual. It will help you with the installation, maintenance, and use of this product.

To the extent permitted by law Kistler does not accept any liability if this instruction manual is not followed or products other than those listed under Accessories are used.

Kistler offers a wide range of products for use in measuring technology:

- Piezoelectric sensors for measuring force, torque, strain, pressure, acceleration, shock, vibration and acoustic-emission
- Strain gage sensor systems for measuring force and torque
- Piezoresistive pressure sensors and transmitters
- Signal conditioners, indicators and calibrators
- Electronic control and monitoring systems as well as software for specific measurement applications
- Data transmission modules (telemetry)
- Electromechanical NC joining modules and force-displacement monitors
- Test bed systems for electric motors and gear units for laboratory, manufacturing, and quality assurance

Kistler also develops and produces measuring solutions for the application fields engines, vehicles, manufacturing, plastics and biomechanics sectors.

Our product and application brochures will provide you with an overview of our product range. Detailed data sheets are available for almost all products.

If you need additional help beyond what can be found either online or in this manual, please contact Kistler's extensive support organization.

## 2. Important Information

### 2.1 Disposal Instructions for Electrical and Electronic Equipment

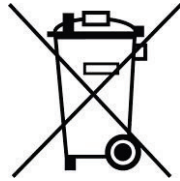

Do not discard old electronic instruments in municipal trash. For disposal at end of life, please return this product to an authorized local electronic waste disposal service or contact the nearest Kistler Instrument sales office for return instructions.

### 3. Application and Key Features

- Measuring ranges from 1 ... 1 000 N·m
- Speed up to 10 000 min<sup>-1</sup>
- Torque meter with strain gages measuring system
- Wear-resistant transmission of the measuring signal, integrated amplifier
- Measurement of constant and variable torques
- Torque measurement on the rotating shaft
- Integrated speed measurement
- Application in the laboratory, manufacture and quality control
- Great value for money

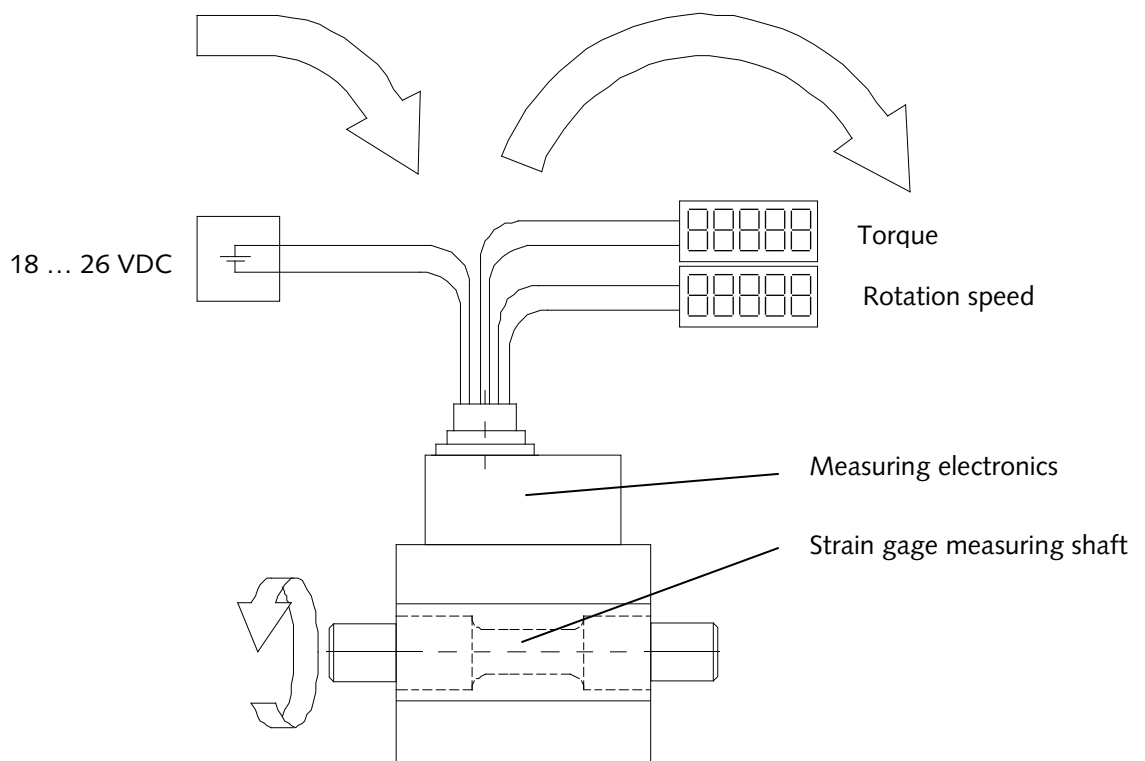

Fig. 1: Basic Line torque sensor Type 4520A...



## 4. Description of the Measuring System

### 4.1 Mechanical Design

Basic Line torque sensors Type 4520A... consist of a base body which contains the measuring shaft. On the measuring shaft there is a torsional section with strain gages and electronics with signal amplifier and A/D transformer. The connection box of the base body contains the stationary electronics for the signal formation. The base body of the sensor offers different assembly positions.

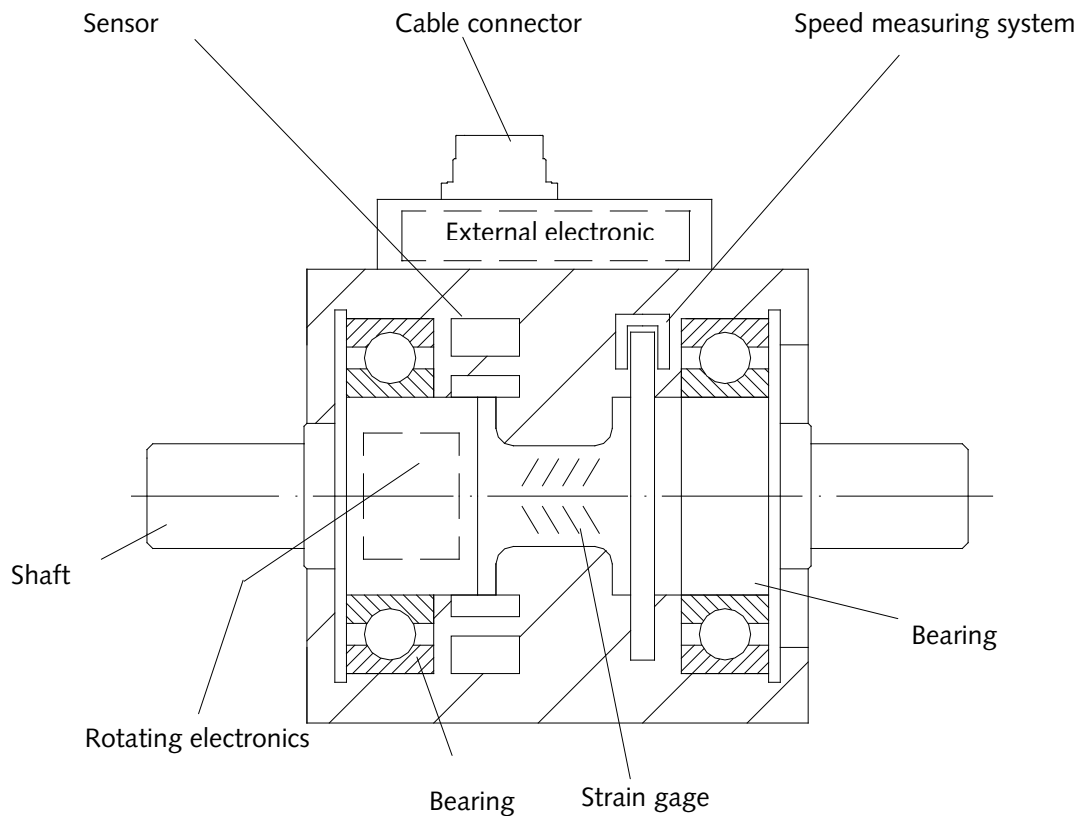

Fig. 2: Mechanical design Basic Line torque sensor Type 4520A...

## 4.2 Electrical Block Diagram

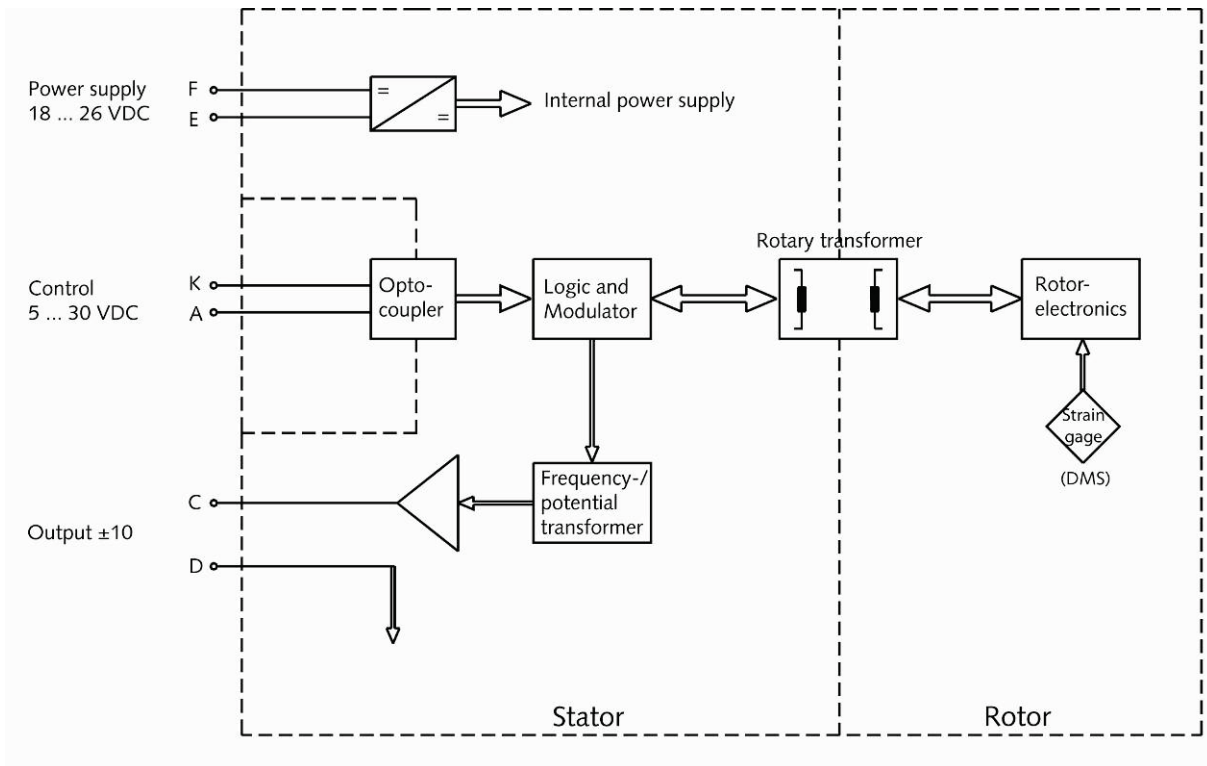

Fig. 3: Electrical block diagram

### 4.2.1 Examples of Application

Strict use of electrical isolation for feed and measuring signal.

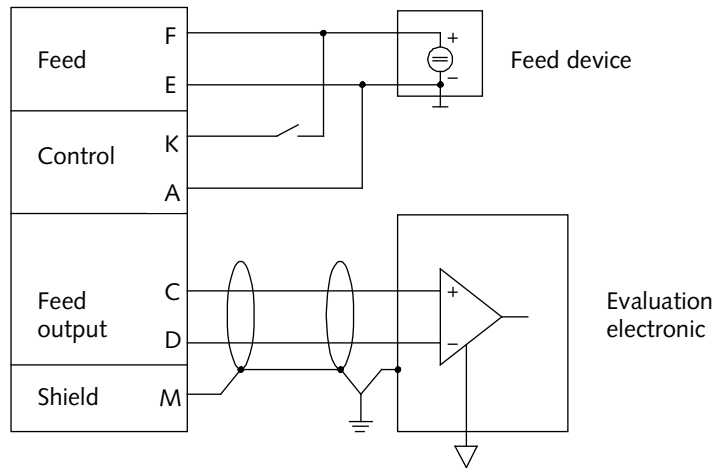

Fig. 4: Separate speed and measuring supply

Shared access measuring supply for feed and measuring supply.



Interlink the power and measuring supply, evaluation electronic is to be made.

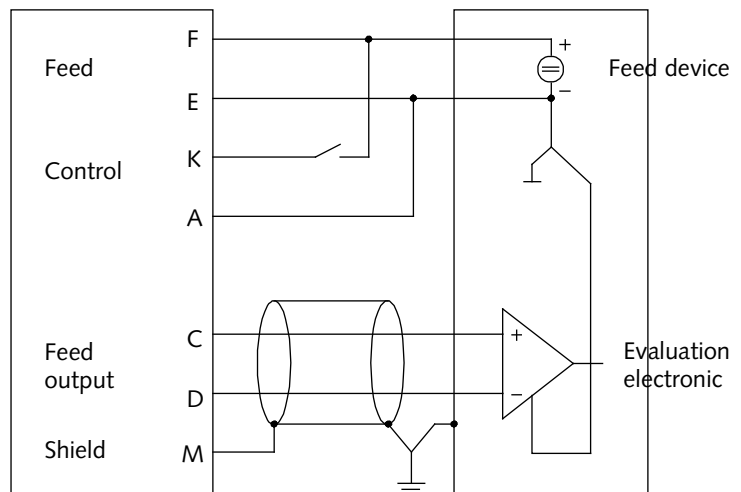

Fig. 5: Power and measuring supply in the evaluation electronic combined

### 4.3 Electrical Configuration of Speed Measurement



Speed measurement is effected photo-electrically by evaluating the light, which shines through a grid wheel.

A gallium-arsenide light diode serves as transmitter emitting in the near infrared. In a phototransistor the light is converted into an electric signal and after a pulse shaper made available as "open collector" signal. The input current amounts max. 16 mA.

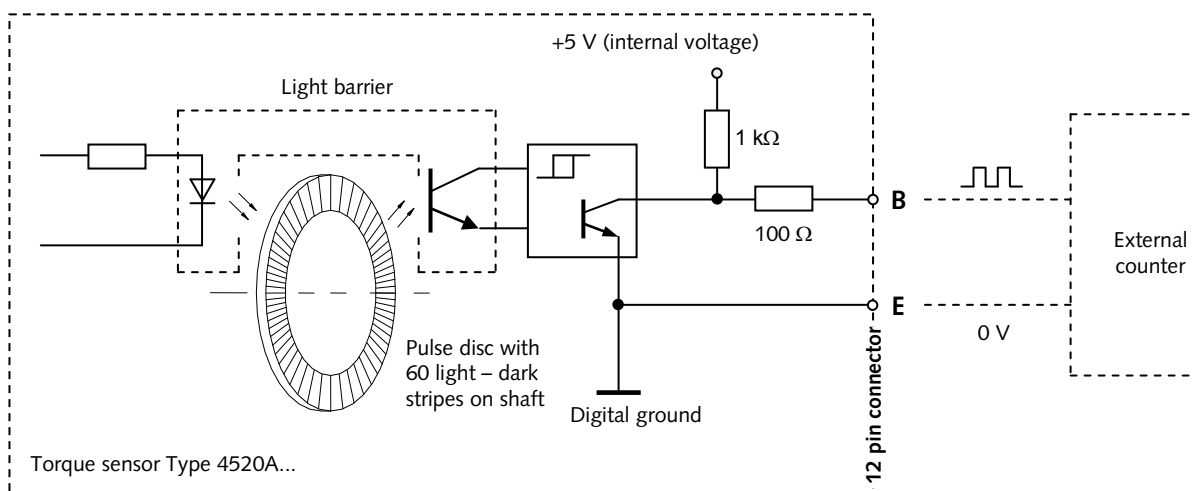

Fig. 6: Electrical block diagram of speed measurement

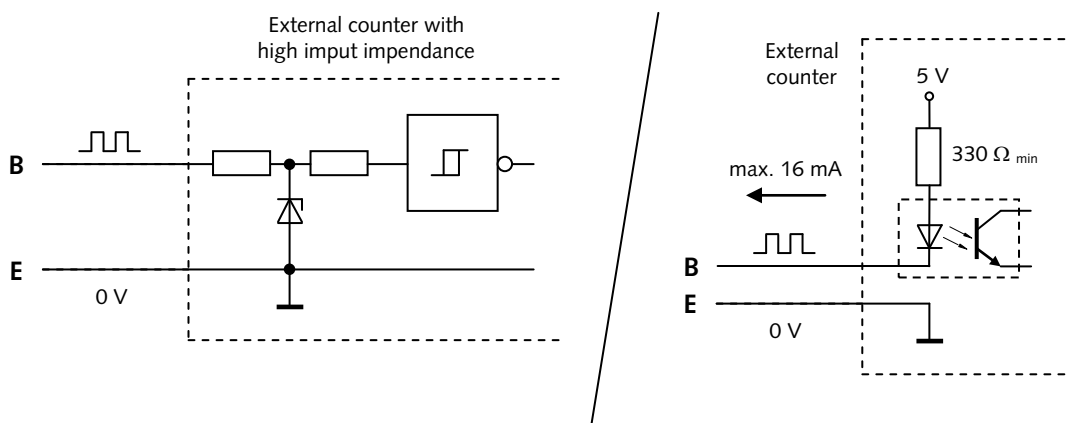

Fig. 7: Electrical CMOS- or TTL input circuit/optically isolated input circuit

## 5. Electrical Connections of the Sensor

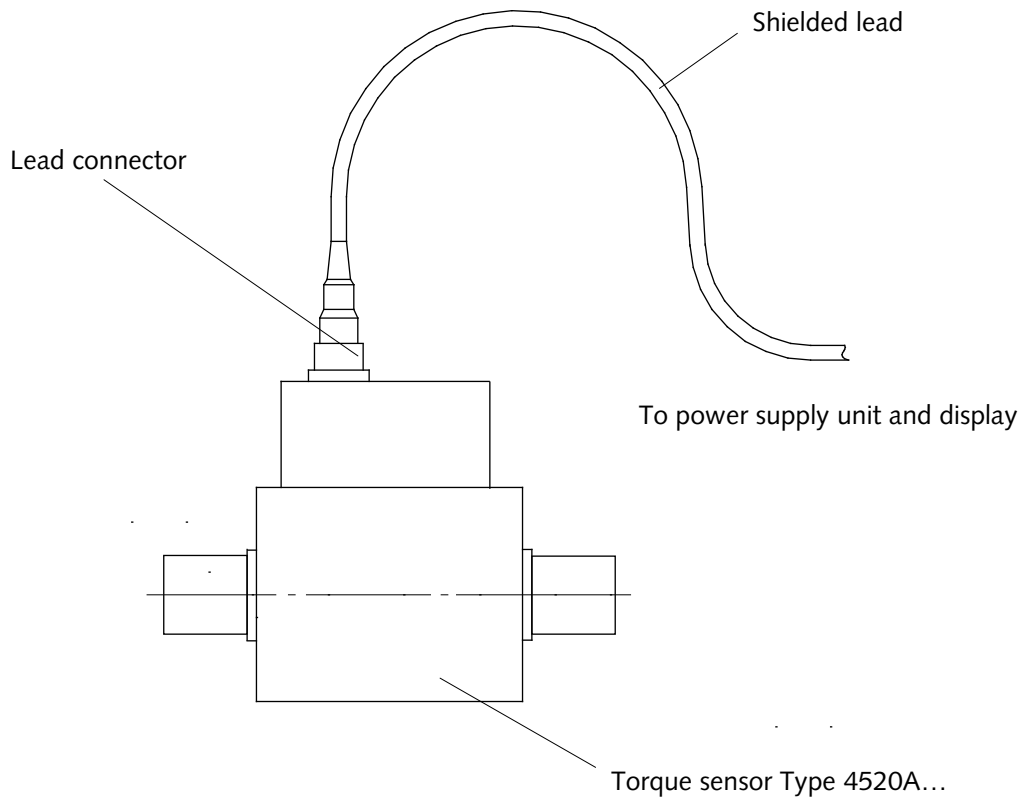
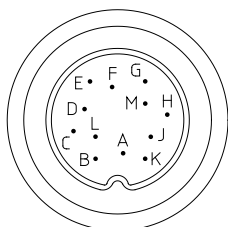

Fig. 8: Electrical connections

- Shielded lead of 0,14 mm<sup>2</sup> nominal cross section

## 5.1 Plug Connection

### Pin Allocation of Built-in 12 pin Connector



Function	Pin	Description	
Power Supply	F	+U <sub>B</sub>	18 ... 26 VDC, power consumption <2 W
	E	GND	Reference for U <sub>B</sub> and angle signals
Shield	M		In sensor; connected to case
Torque output	C	U <sub>A</sub>	±10 VDC at M <sub>nom</sub> at >2 kΩ 10 VDC at control signal revolution R <sub>i,C</sub> = 10 Ω, output with short-circuit protection connection to AGND
	D	AGND	Reference for U <sub>A</sub>
Speed sensor	B	Track A	Open collector output Internal 1 kΩ resistance to 5 VDC (pull up), TTL-level
Input 100 % control input	K	Control	Off: 0 ... 2 VDC On: 5 ... 30 VDC
	A	KGND	Reference for control
	G		Reserved
	H		Reserved
	J		Reserved
	L		Reserved

#### 5.1.1 Installing the Signal Lead

- Do not run the lead parallel to power cables or control circuits.
- Do not place the lead close to equipment producing strong electromagnetic fields, e.g. transformers, welders, contactors, electric motors, etc.
- If such situations cannot be avoided, run the lead inside earthed steel conduit.
- Make a loop in the lead when fixing it at the torque sensor so that it is not damaged by vibration.
- If supply and evaluation unit are galvanically connected, a differential input must be used for the torque signal to prevent that the voltage drop on the 0 V-supply line affects the measured signal.

## 5.2 Instruction for Electrical Installation

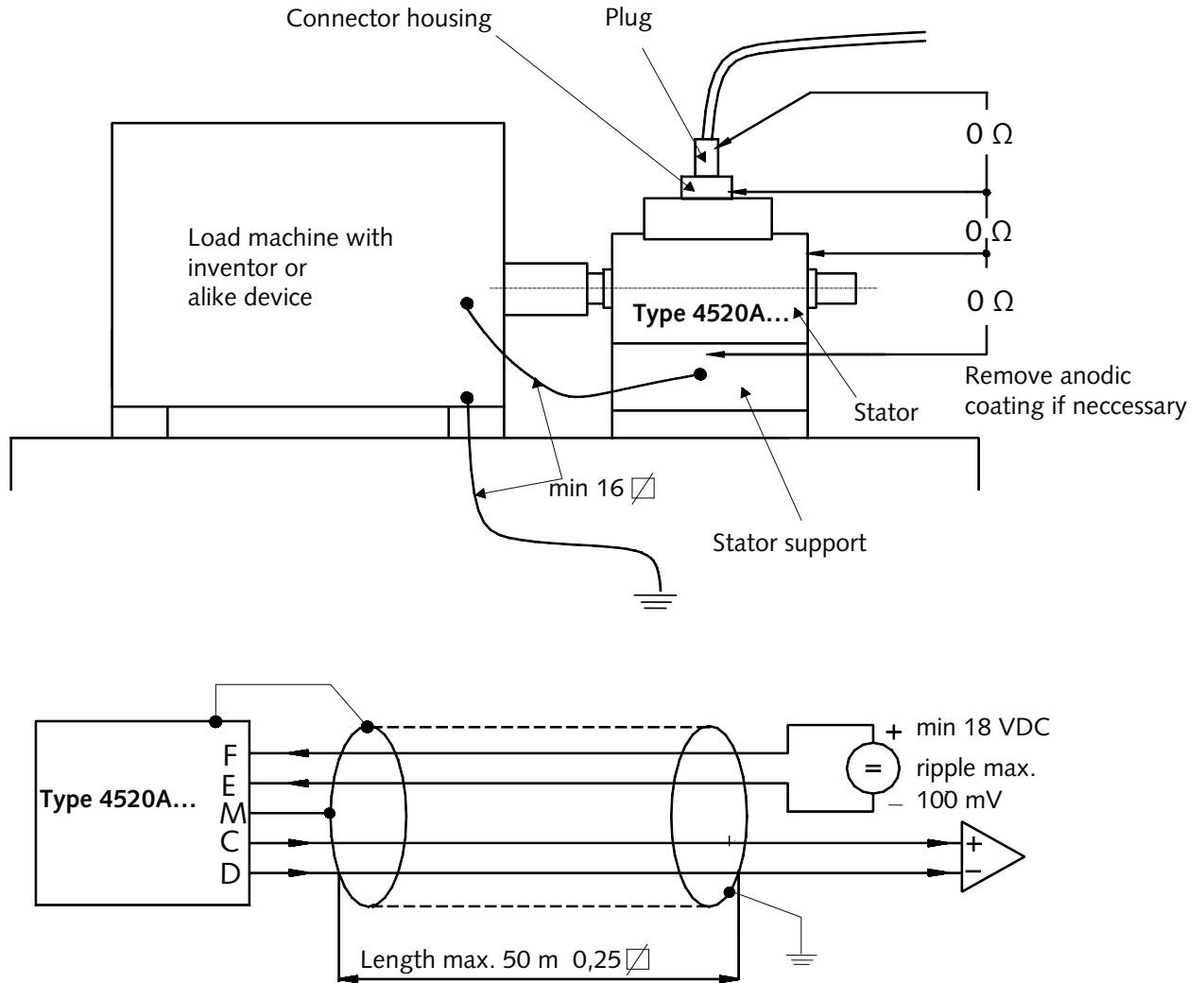

Fig. 9: Electrical installation



- Please ensure correct functioning of the shield for the connection cable!
- To improve the electrical contact area between stator housing base and machine base, it's recommended to remove the anodization of the bottom of the stator housing.

### 5.3 Connection Cables

**12 pin standard cable**

Fixed length 5 m  
Type KSM072030-5  
Material-No.: 18008943

Definable length  
Type KSM072030-5  
Material-No.: 18008935

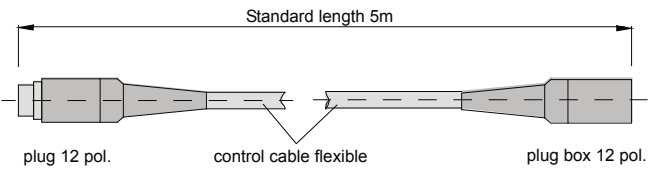

A	white/brown	GND	Ground for supply voltage U <sub>B</sub>	A
B	red	TXD	RS 232 to UMV2000	B
C	violet	U <sub>A</sub>	Torque value output +/- 5 VDC	C
D	black	AGND	Ground for torque value output U <sub>A</sub>	D
E	brown	DGND	Ground for speed, angle, RS 232, control	E
F	blue	U <sub>B</sub>	Supply 11 ... 30 VDC, approx. 2.5 W	F
G	pink	Track B	Angle output 90° after Track A (optional)	G
H	white/green	Track A	Speed output, angle output (optional)	H
J	green	Track Z	(not used)	J
K	white	control	input, activated with: 3.5 ... 30 VDC	K
L	yellow	RXD	RS 232 from UMV 2000	L
M	grey	Housing		M

---

**12 pin standard cable with open-ends**

Fixed length 5 m  
Type KSM124970-5  
Material-No.: 18008943

Definable length  
Type KSM124970-5  
Material-No.: 18008943

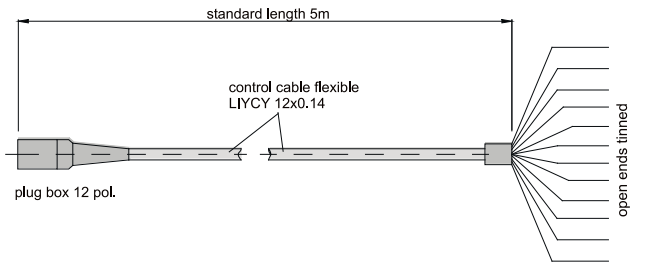

A	GND	Ground for supply voltage U <sub>B</sub>	violet
B	TXD	RS 232 to UMV2000	yellow
C	U <sub>A</sub>	Torque value output +/- 5 VDC	pink
D	AGND	Ground for torque value output U <sub>A</sub>	grey
E	DGND	Ground for speed, angle, RS 232, control	blue
F	U <sub>B</sub>	Supply 11 ... 30 VDC, approx. 2.5 W	red
G	Track B	Angle output 90° after Track A (optional)	green
H	Track A	Speed output, angle output (optional)	black
J	Track Z	(not used)	white
K	control	input, activated with: 3.5 ... 30 VDC	white/green
L	RXD	RS 232 from UMV 2000	brown
M	Housing		

4520A\_002-515e-01.14

Page 13



## 5.4 Mechanical Installation of the Torque Sensor

There are different methods of installing the torque sensor, depending on the application.

Since very high lateral forces and bending moments may occur even at small axial displacement, the torque sensor must always be mounted with couplings.

### Generally

- The plant must be secured with a burst protection corresponding to the machine protection law.
- We recommend calculating the shafting according to the torsion- and bending critical speeds. These speeds should be avoided during operation. For a safe operation of the unit we recommend to remain approx. 30 % below or above the critical speeds.
- After installation depending on speed the unit should be balanced according to DIN 2060.
- The machine vibrations should be checked according to VDI 2056.



### Literature

Dubbel pocket book for machine engineering, published by Springer.

F. Holzweißig, H. Dresig, textbook of machine dynamics, published by Springer.

DIN 2056 evaluation rules for mechanic vibrations of machines.

### 5.5 Possible Installation Type 4520A...

Torque sensor between drive and brake

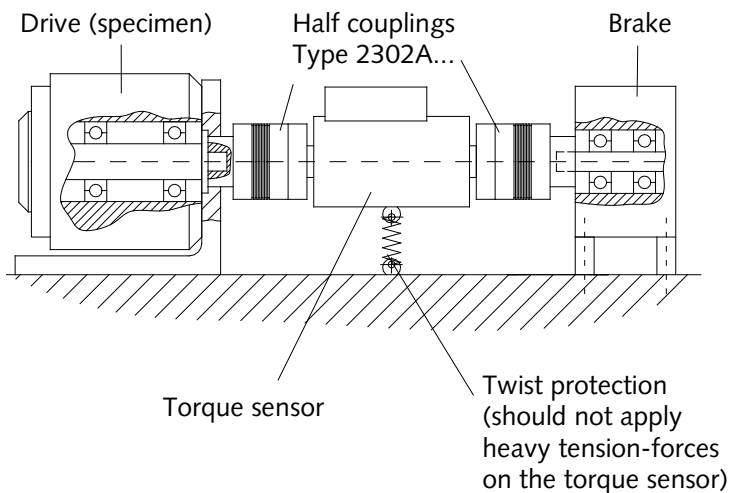

Fig. 10: Together with the half couplings the torque sensor forms a full coupling

Couplings compensate for axial-radial and angular misalignment.

The connection of shaft and coupling hub is positively locked by a clamping element.

The torque measuring shaft is only a part of the power train. Radial and torsional vibrations may have a very bad impact on the performance of the torque shaft and the measuring signal.

For that reason the operating speed must not be near the critical speed, either it has to be far underneath or above it.

## 6. Mechanical Application and Mechanical Installation of the Torque Sensor Type 4520A...

### 6.1 Frictional Torque Control in Production

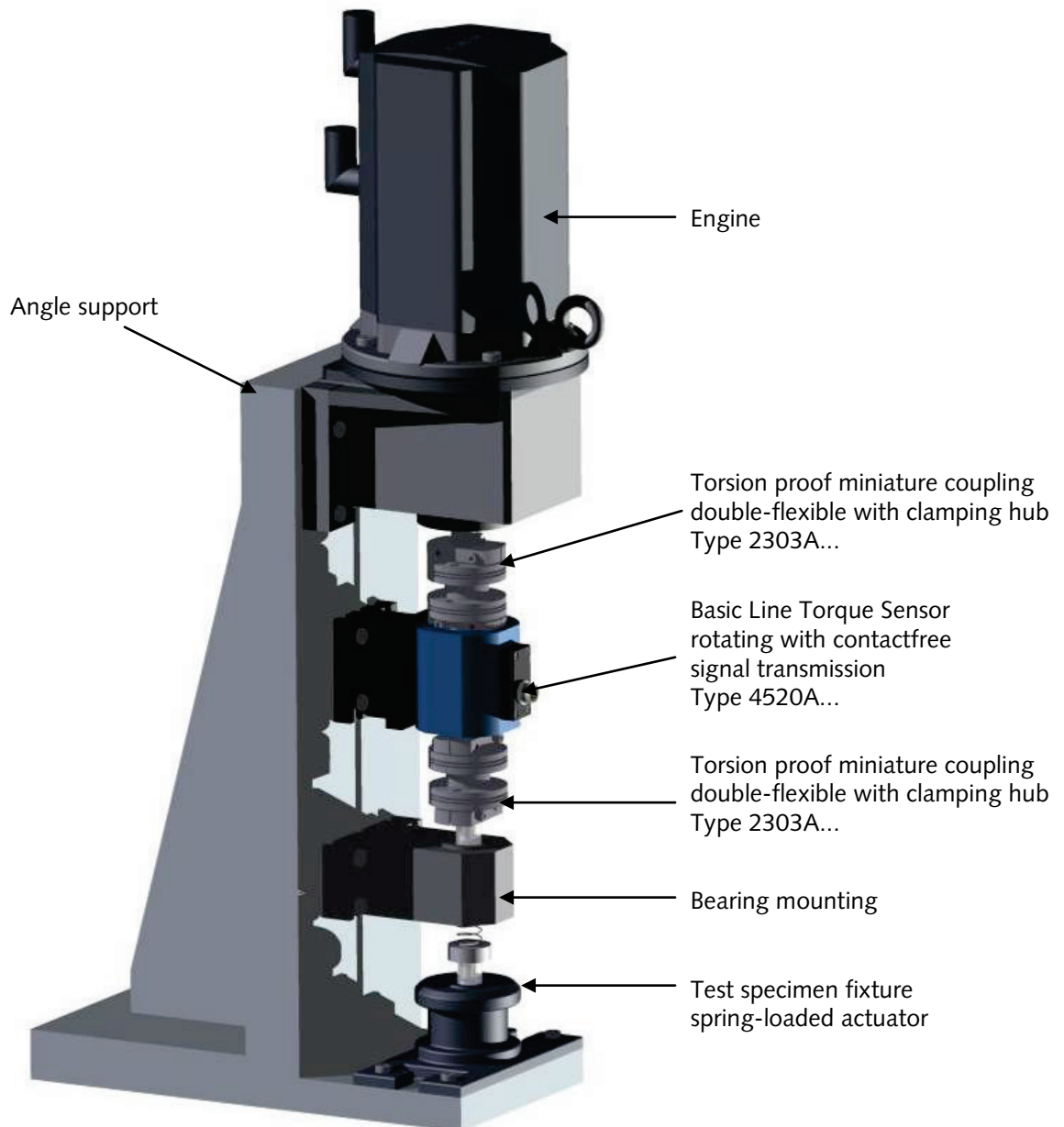

Fig. 11: Application example Type 4520A...

## 6.2 Torque Measuring Shaft Version RA



Type 4500B...

For the electric connection of measuring shaft and supply- and evaluation unit we recommend to use the shielded signal lead, Type KSM072030-5 (Mat. No.: 18008943) with low capacity.

As supply and evaluation unit we suggest the Control Monitor CoMo Torque Type 4700B... . The matching connection cable is Type KSM018538-2,5 (Mat. No.: 18008963).



Type 4704A...

As an alternative solution the units Type 4704A..., model VA3600 without display can be used. Assembly set Type KSM035681 (Mat. No.: 18024830) as accessories for VA3600 for the connection of the torque measuring shaft Type 4520A... .

The signal lead should not exceed a length of 30 meters. Do not run the lead parallel to power cables or control circuits. The pin connection is explained in chapter "Plug Connection" of this manual.

On each side of the torque measuring shaft there is a high quality bearing installed. The installation can have any position, however offset couplings must always be applied to balance geometrical errors and keep false loads away from the torque measuring shaft.

**Radial, axial, diagonal and angular errors are compensated by:**

- Multi-disk couplings, e.g. Type 2303A...
- Membran
- Claw couplings

### 6.3 Supply and Evaluation

The sensor may only be operated using filtered 24 VDC voltage.

Recommended supply voltage:

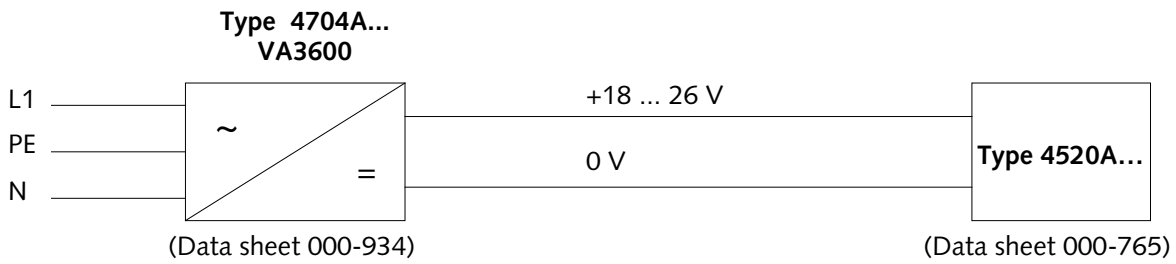

Terminal box for Type 4520A...

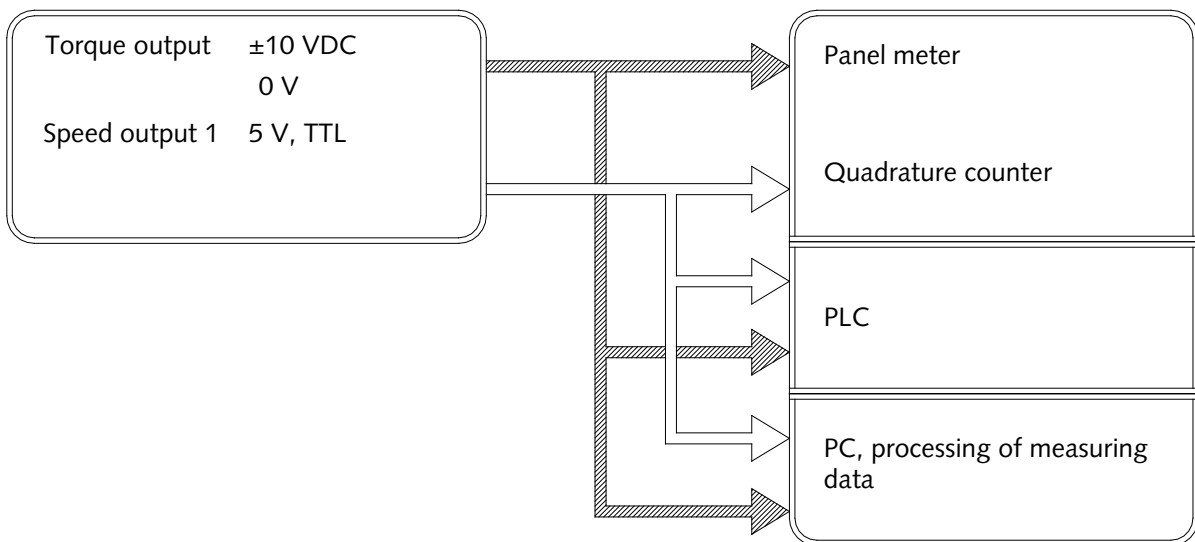

Fig. 12: Supply circuit and evaluation

## 7. Static Calibration

This procedure requires the use of a calibration device with a lever arm and weights for producing specific values of torque.

### The calibration procedure is as follows

- Apply the rated value of torque to the torque meter and then remove it again
- Adjust the zero reading accurately
- Apply a known value of torque to the torque meter
- Adjust the displayed reading to the corresponding value

### Plotting a calibration curve

- Calibrate the torque meter as described above
- Apply torque in 1/10 steps up to the full rated value and then remove it again in the same way.
- A delay of at least 30 seconds must be allowed between the individual 1/10 steps so that each reading can stabilize before it is recorded.

### 7.1 Construction of a Simple Calibration Device

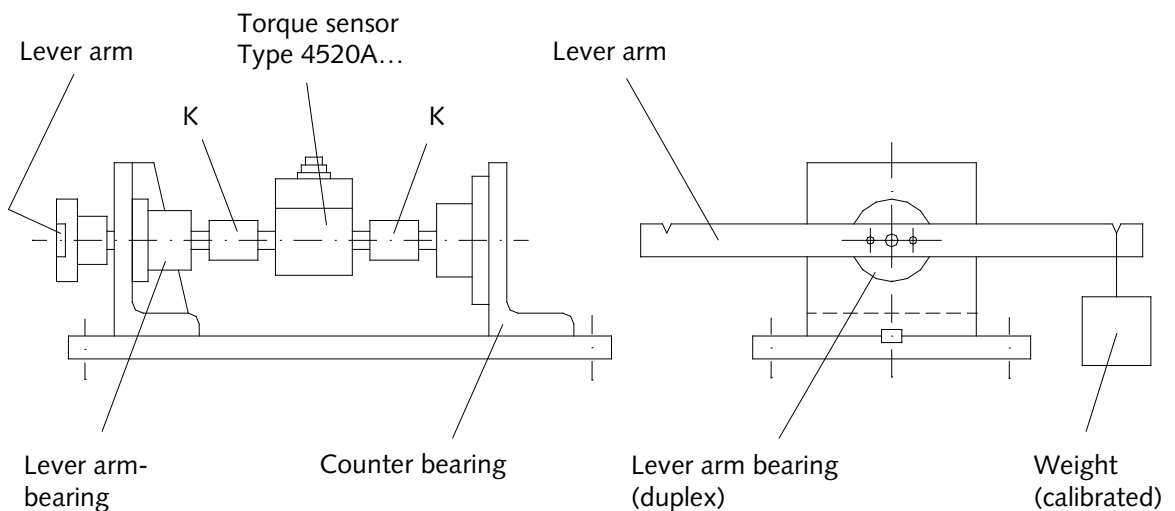

K = loose half-couplings

Fig. 13: Calibration device

## 7.2 Calculation Example for Lever Arm Length

$$L = \frac{M}{m \cdot g}, \text{ whereby}$$

- M = Torque
- L = Length of lever arm required
- m = Mass required
- g = 9.80665 m/s<sup>2</sup>  
(= standard gravity – varies with location)

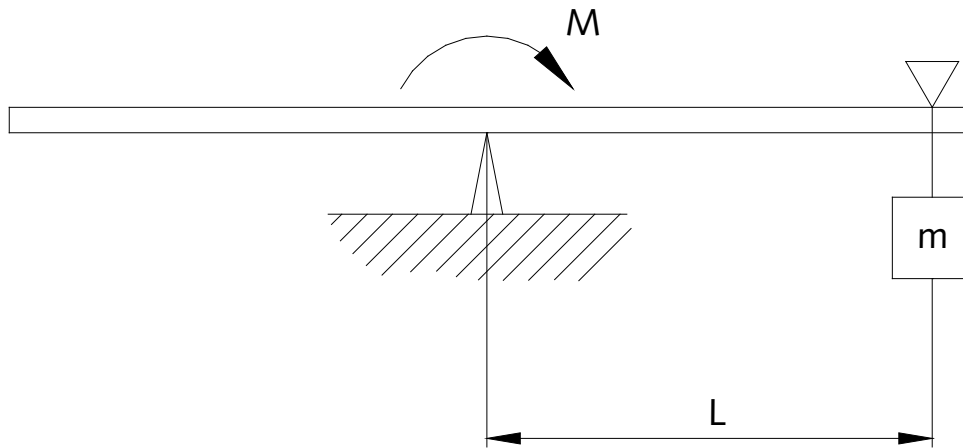

Fig. 14: Calculation of lever arm length

**Example:** m = 1 kg  
Mt = 10 N·m

$$\rightarrow L = \frac{10 \text{ N} \cdot \text{m}}{1 \text{ kg} \times 9,80665 \text{ m/s}^2} = 1,0197 \text{ m}$$

## 8. Maintenance

- Sensors of the Type 4520A... are almost maintenance-free.
- Durability of bearings in rated temperature range is approx. 20 000 hours.
- Durability of bearings in working temperature range is approx. 10 000 hours.
- Renewal of bearings can only be effected at works.
- Precision applications: Yearly calibration of sensor (calibration at works or with adequate calibration device).
- Control correct cable plug position monthly.
- Check cables for damages monthly.
- Annual re-calibration of torsional moment



## 9. Repairs

Fault	Cause	Remedy
Shaft stiff to turn	Bearing defect due to a) torsional or flexural vibration b) high axial or radial loads c) worn bearings d) bent shaft	Return to factory
Zero shift less than 2 %	Torsional vibration Torsional shock	The zero reading can be readjusted at the display.
Zero shift between approx. 2 and 5 % of full scale	Sensor overloaded Torsional vibration Puch moments	The zero reading can be readjusted once at the display.
Hysteresis between clockwise and anticlockwise torque	Sensor overload through high dynamic load or torsional vibration.	Return to factory

## 10. Declaration of Conformity



### EC Declaration of Conformity EG-Konformitätserklärung Déclaration de conformité CE

Manufacturer Hersteller Fabricant	<b>Kistler Lorch GmbH 73547 Lorch Germany</b>
---	---

declares that the product/erklärt, dass das Produkt/déclare que le produit

Name/Name/Nom	<b>Torque Sensor/Drehmomentsensor/Torque Capteur</b>
Type/Typ/Type	<b>4520A...</b>
Modules/Module/Modules	-
Options/Optionen/Options	<b>all/alle/toutes</b>

relates with the following standards/mit den folgenden Normen übereinstimmt/  
est conforme aux normes suivantes

EMC Emission EMV Störaussendung Emission EMC	<b>EN 61000-6-4:2011-09</b>	<b>(Class A)</b>
EMC Immunity EMV Störfestigkeit Immunité EMC	<b>EN 61000-6-2:2006-03</b>	

Following the provisions of directive/Gemäss den Bestimmungen der Richtlinie/Conformément  
aux dispositions de directive

**2004/108/EG** **(EMC / EMV / EMC)**

Lorch, January 2014

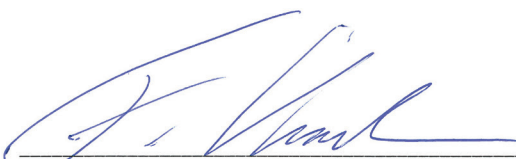

\_\_\_\_\_  
Franz Winter  
General Manager

## 11. Accessories and Ordering Key

### Ordering Key

#### Measuring Range in N·m

1	001
2	002
5	005
10	010
20	020
50	050
100	100
200	200
500	500
1 000	1k0

Type 4520A



### Ordering Example

Type 4520A010

Torque sensor: Rated torque 10 N·m: **010**

### Included Accessories

- None

### Optional Accessories

- |   | Type/Art. No. |
|---|---------------|
| • Female cable connector with solder lug 12 pin   | KSM000703     |
| • Connecting cable, length 5 m, 12 pin – flying leads   | KSM124970-5   |
| • Connecting cable, length 2,5 m, 12 pin – CoMo Torque  | KSM185380-2,5 |
| • Control Monitor CoMo Torque evaluation instrument for torque sensors (see data sheet 4503A_000-595) | 4700B...      |
| • Connecting cable, length 5 m 12 pin neg. – 12 pin pos.  | KSM07203-5    |

## 12. Index

### A

Accessories and Ordering Key .....	24
Application/Key Features.....	5
Applikationsbeispiele .....	8

### C

Calculation Example for Lever Arm Length	20
Construction Calibration Device .....	19

### D

Declaration of Conformity .....	23
Description of the Measuring System .....	6
Disposal Instructions.....	4

### E

Electrical Block Diagram.....	6
Electrical Configuration of Speed Measurement	9
Electrical Connections of the Sensor .....	10
Examples of Application .....	8

### F

Frictional Torque Control in Production .....	16
---	----

### H

Help .....	3
------------	---

### I

Important Information .....	4
Installing the Signal Lead .....	11
Instruction for Electrical Installation.....	12
Introduction .....	3

### M

Maintenance.....	21
Mechanical Application and Mechanical Installation.....	16
Mechanical Design.....	6
Mechanical Installation .....	14

### P

Plug Connection .....	11
Possible Installation Type 4520A.....	15

### R

Repairs.....	22
--------------	----

### S

Static Calibration.....	19
Supply and Evaluation.....	18

### T

Torque Measuring Shaft Version RA .....	17
---	----