

OPERATION MANUAL

Load Cell and Torque Sensor – X/Y/Z Model 8565

© 2024 burster
präzisionsmesstechnik gmbh & co kg
All rights reserved

Manufacturer:
burster
präzisionsmesstechnik gmbh & co kg
Talstrasse 1 - 5 Postfach 1432
76593 Gernsbach 76587 Gernsbach
Germany Germany

Valid from: January 26, 2024

Tel.: +49 7224 645-0
Fax: +49 7224 645-88
Email: info@burster.de
www.burster.de

Warranty disclaimer

All information in the present documentation was prepared and compiled with great care and reproduced in accordance with effective control measures. No warranty is provided for freedom from errors. We reserve the right to make technical changes. The present information as well as the corresponding technical data can change without notice. Reproduction of any part of this documentation or its processing or revision using electronic systems is prohibited without the manufacturer's prior written approval.

Components, devices and measurement sensors made by burster präzisionsmesstechnik (hereinafter referred to as the "product") are the result of targeted development and meticulous research. From the date of delivery, burster provides a warranty for the proper condition and functioning of these products covering material and production defects for the period specified in the warranty document accompanying the product. However, burster waives any guarantee or warranty obligations or any additional liability for consequential damages caused by improper use of the product, in particular the implied guarantee of success in the market as well as the suitability of the product for a particular purpose. Furthermore, burster assumes no liability for direct, indirect or incidental damages or for consequential or other damages arising from the provision and use of the present documentation.

Contents

1	Introduction.....	5
1.1	Purpose of this manual	5
1.2	Applicability of the manual	5
1.3	Target group.....	5
1.4	Presentation of information	5
1.5	Warranty.....	5
2	Reliability.....	7
2.1	Applications.....	7
2.1.1	Intended use	7
2.1.2	Restrictions on use	7
2.1.3	Operating conditions	7
2.2	Hazard warnings	7
2.3	Requirements for personnel.....	7
3	Description of the sensor.....	8
3.1	Principle of operation	8
3.2	Mechanical design	8
3.3	Requirements for accurate measured values	9
3.3.1	Full-scale deflection	9
3.3.2	Crosstalk	9
3.3.3	Overload	9
4	Planning the desired application.....	10
4.1	Calculating the maximum load.....	10
4.2	Prevent interference.....	10
4.3	Requirements for the workpiece adapter / gripper.....	11
4.4	Requirements for evaluation instruments	11
5	Unpacking / contents of pack / storage	12
5.1	Unpacking	12
5.2	Contents of pack	12
5.3	Storage.....	12
6	Installation.....	13
6.1	Fixing method.....	13
6.1.1	Requirements for fitting.....	13
6.1.2	Fastening the sensor	13
6.1.3	Monitor fitting	13

6.2	Connection	14
6.2.1	Electrical connection	14
6.2.2	Grounding and equipotential bonding	15
6.2.3	Connection to evaluation instruments	15
7	Using the sensor for the first time	17
8	Operation	18
8.1	Measurement chain calibration	18
8.2	Applying the force	18
8.3	Monitor operation	19
8.3.1	Overload	19
9	Maintenance and cleaning	20
9.1	Recalibration	20
9.2	Cleaning	20
10	Technical data	21
10.1	Ambient conditions	21
11	Accessories	21
12	Customer service	21
13	Disposal	22
14	Declaration of Conformity	23
15	Appendix	24

1 Introduction

1.1 Purpose of this manual

This operation manual is intended to help familiarize you with the device and obtain the full functional benefit from its capabilities.

The operation manual contains important information for the safe, proper and effective use of the device. Follow the instructions carefully to reduce repair costs and downtime, and to increase the reliability and service life of the device.

1.2 Applicability of the manual

This operation manual applies exclusively to the model 8565 load cell and torque sensor (henceforth: "sensor").

1.3 Target group

This operation manual is intended for personnel who install and operate the sensor.

1.4 Presentation of information

To enable you to work quickly and safely with this manual, standardized formatting, figures, symbols, warnings (see section 2.2), terms and abbreviations are used.

► Instructions are indicated by an arrow.

Note: These notes should be observed to ensure correct handling of the sensor.

IMPORTANT: Follow the information given in the operation manual.

1.5 Warranty

burster präzisionsmesstechnik gmbh & co kg provides a manufacturer's warranty for a period of 24 months after delivery.

Any repairs required during this time will be made without charge. This does not include damage arising from improper use.

Please note the following when sending the sensor in for repair:

- If there is a problem with the sensor, please attach a note to the body of the device summarizing the fault.
- Technical specifications subject to change at any time without notice. We also state explicitly that we do not accept liability for consequential damage.
- The sensor must always be shipped in suitable packaging.

Conversions and modifications

Note: The warranty shall be deemed void **immediately** if you open or dismantle the sensor during the warranty period.

The sensor does not contain any parts that are intended to be serviced by the user. Only the manufacturer's own qualified personnel are permitted to open the sensor.

It is not permitted to make any changes to the sensor without the written agreement of burster präzisionsmesstechnik gmbh & co kg. burster präzisionsmesstechnik gmbh & co kg does not accept liability for damages or injury if this condition is disregarded.

2 Reliability

IMPORTANT: Read the operation manual carefully before using the device, and keep it for future reference.

2.1 Applications

2.1.1 Intended use

The sensor is intended mainly for force/torque measurements in production facilities, units newtons (N) and newtonmeters (Nm). The local acceleration due to gravity ($g \approx 9.81 \text{ m/s}^2$) must be taken into account when determining masses.

2.1.2 Restrictions on use

The sensor does not pose a hazard if used within its specification and in accordance with safety regulations.

The manufacturer does not accept liability for any personal injury or property damage arising from improper installation or operation, or from misinterpretation of measurement results.

2.1.3 Operating conditions

- Only connect the sensor to instrumentation amplifiers equipped with a safety transformer according to EN 61558.
- Transmitters connected to the outputs or other devices that are galvanically connected to the sensor's signal lines must also be fitted with safety transformers according to EN 61558.

2.2 Hazard warnings

In this operation manual, hazard warnings are presented in the following format:

	NOTICE
	<p>Property damage to the equipment or the surroundings will result if the hazard is not avoided.</p> <p>► Observe the advice for protecting the sensor.</p>

2.3 Requirements for personnel

Personnel must be familiar with the relevant regulations. They must follow these regulations. Only trained personnel who are familiar with the applicable safety regulations are permitted to operate the sensor.

3 Description of the sensor

Please refer to the sensor's data sheet for full details of dimensions, weight, degree of protection etc. (see section 15).

3.1 Principle of operation

The sensor has an internal structure which, under deformation, allows forces and torques to be measured by means of strain gages and converted into an electrical signal.

3.2 Mechanical design

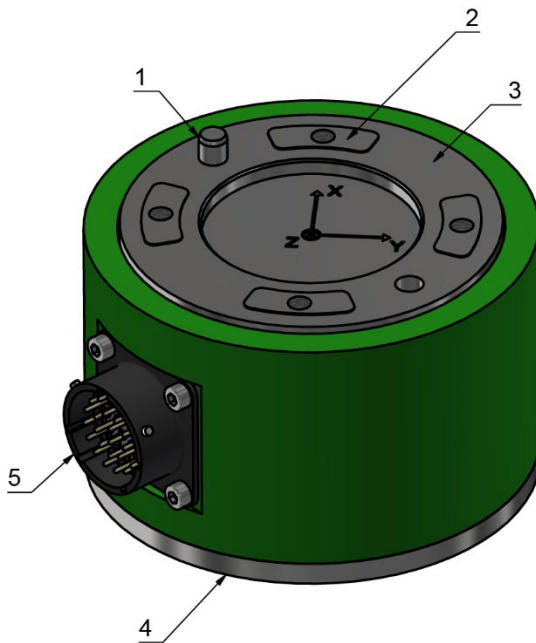

Figure 1: Overview

- 1 Centering pin
- 2 Contact surfaces for force transmission (4x)
- 3 Adapter side
for gripper/workpiece
(robot flange conforms to DIN ISO 9049-1)
- 4 System side
to the system/robot
(robot flange conforms to DIN ISO 9049-1)
- 5 Connector

3.3 Requirements for accurate measured values

3.3.1 Full-scale deflection

The applied forces and torques deform the sensor by approx. 15 µm to 40 µm, depending on the load direction. This deformation is known as the “full-scale deflection”, and is so small that it cannot be seen with the naked eye.

3.3.2 Crosstalk

Crosstalk means the mutual influence of the individual channels on each other. If one component is loaded, the other channels show a very small, unwanted signal.

It is only possible to specify the crosstalk if the sensor measures several components (forces F_x , F_y , F_z or torques M_x , M_y , M_z).

The quality of the contact surfaces of the equipment to which the sensor is attached will affect the signal. The requirements for the contact surfaces are described in section 4.3.

It is also important to observe the tightening torques while fitting the sensor to minimize undesirable effects (see section 6.1.2).

3.3.3 Overload

To prevent any danger to operating personnel or damage to the sensor, care must be taken to ensure that the sensor is not subjected to loads exceeding the maximum operational force defined in the data sheet.

Due to the mass of attachments, tools or the test object, high forces and torques can occur on the sensor as a result of rapid accelerations.

The maximum permissible load (L_{max}) can be calculated using the formula in the data sheet (see sections 4.1 and 15).

If, despite precautions, the sensor has been overloaded, you will notice this immediately by a change in the output signal for the zero point.

	NOTICE
	<p>A large mass and its acceleration can generate large forces extremely quickly.</p> <ul style="list-style-type: none"> ▶ Avoid sudden loads (impulses) and strong accelerations with large masses under all circumstances.

	NOTICE
	<ul style="list-style-type: none"> ▶ Get the sensor checked if you notice a change in the signal of 5 % or more (higher or lower) while no load is present.

4 Planning the desired application

4.1 Calculating the maximum load

The maximum limit value (L_{max}) must not be exceeded with dynamic loads. The formula for calculating L_{max} can be found in the data sheet (see section 15).

Use the formula to add up the maximum occurring force and torque vectors with a weighting factor. The calculated value for L_{max} must remain smaller than the value specified in the data sheet.

Please note that the sensor's coordinate origin is located at the geometric center of the sensor. When calculating the maximum operational force, the additional bending moments due to leverage effects must be taken into account for the acting lateral forces.

4.2 Prevent interference

The sensor supplies a very small output voltage signal proportional to the applied force and torque.

To prevent interference, the shield of the connecting cable must be connected to ground with low impedance to ensure good protection.

The leads should be routed well clear of possible sources of interference such as electric motors or frequency converters.

NOTICE



Damage due to vibration

Vibrations and external forces can cause falsified measurement results.

- ▶ Avoid vibrations, even if the loads generated by them remain below the rated load.
- ▶ Design your measuring system in such a way as to prevent these external forces.

4.3 Requirements for the workpiece adapter / gripper

The maximum occurring forces and torques depend on the weight and shape of attached parts, as well as their orientation during acceleration.

Contact surfaces

A high quality measurement depends on a defined deformation of the measuring element under load. To prevent unwanted deformations, the upper and lower contact surfaces of the sensor (see section 3.2) must rest on the mounting surface.

The mounting surface must meet the following requirements:

- adequately stable
- hardened, minimum hardness 60 HRC
- ground, preferably lapped, surface quality: $R_a \leq 0.8$, evenness 10 μm
- not coated in any material
- must contain no holes or milled slots, nor any centering holes

4.4 Requirements for evaluation instruments

Use electronic or evaluation instruments suitable for strain gages.

Information is available at <https://www.burster.de/en> and from burster Technical Service (see <https://www.burster.de/en/load-cells>).

5 Unpacking / contents of pack / storage

5.1 Unpacking

	NOTICE
	<ul style="list-style-type: none"> ▶ Never connect the sensor if it shows signs of damage incurred in transit. ▶ Only ever use sensor under the conditions specified in this operation manual.

- ▶ Inspect the sensor for damage. If you suspect that the unit has been damaged during shipping, notify the delivery company within 72 hours.

The packaging should be retained by a representative of the manufacturer and/or the delivery company.

The sensor should be transported only in its original packaging or in packaging capable of providing an equivalent degree of protection.

5.2 Contents of pack

- Model 8565 load cell and torque sensor
- Test certificate
- + 26-pin mating connector

5.3 Storage

The sensor must be stored under the following conditions only:

- dry
- no condensation
- temperature between 0 °C and 60 °C

Note: Provided the storage conditions have been observed, no special steps need to be taken after storage and prior to using the sensor.

6 Installation

6.1 Fixing method

6.1.1 Requirements for fitting

Screws

- ▶ Use only screws with the properties specified in the data sheet (see section 15).

Mounting surfaces

- ▶ Make sure that all mounting surfaces meet the requirements described in section 4.3.

6.1.2 Fastening the sensor

We recommend centering the sensor via the inner centering surface $\varnothing 46$ H7.

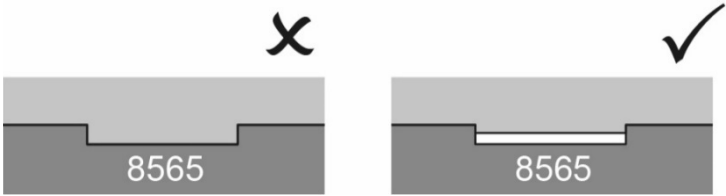
NOTICE	
	<p>The inner centering surface is only intended for centering via the sides. Any transmission of force via the end faces must be avoided.</p> <ul style="list-style-type: none"> ▶ When centering, make sure that the mating part does not completely fill the inner centering surface (see schematic drawing). <div style="text-align: center; margin-top: 10px;">  </div>

- ▶ For positioning, use one of the supplied positioning pins $\varnothing 6$ H8.
- ▶ For the flange screws, observe the tightening torques specified in the data sheet (see section 15).
- ▶ Avoid torsional, transverse and bending forces while fitting the sensor.

6.1.3 Monitor fitting

- ▶ Monitor the sensor's output signals during installation via a display to detect and prevent possible improper loads during installation at an early stage.

You can recognize an overload from an increased output signal at no load (see section 3.3.3).

Note: Check the sensor if the signal increases by more than approx. 5 %.



NOTICE

- ▶ Do not apply sudden loads to the sensor.

6.2 Connection



This is how it works

- ▶ Install the cables so that they do not vibrate.
- ▶ Ensure sufficiently large bending radii for the cables.



NOTICE

- ▶ Relieve the bending stress exerted by the connecting cable on the plug connector at the sensor housing.
- ▶ Avoid pulsating or alternating loads on the cable sleeve.
- ▶ Avoid any cable vibration to prevent damage to the cable sheath.
- ▶ Protect the cables from strain.
- ▶ Protect the sensor from vapors and liquids.

6.2.1 Electrical connection

- ▶ Position the sensor, cables and measuring instrument outside of the electromagnetic field of high-energy equipment. This includes transformers, motors, contactors, frequency converters and so forth. Otherwise the electromagnetic fields from such equipment will act with their full effect on the measuring chain, causing incorrect measurements.
- ▶ Route the measuring leads separately from power cables.
- ▶ If the measuring leads are laid parallel to power cables, the latter will cause inductive and capacitive interference.

Note: You can place an extra screen over the measuring cables for additional protection, or run them through a metal tube or pipe.

6.2.2 Grounding and equipotential bonding

All connecting wires (including the cable screening braid) are electrically insulated from the sensor body. The insulation resistance between the connecting wires and the sensor body is measured. The test certificate states that the minimum resistance is greater than 30 MΩ (test voltage 45 V).

	NOTICE
	<p>▶ Only connect the sensor to instrumentation amplifiers equipped with a safety transformer according to EN 61558.</p>

Note: Transmitters connected to the outputs or other devices that are galvanically connected to the sensor signal lines must also be fitted with safety transformers according to EN 61558.

6.2.3 Connection to evaluation instruments

	NOTICE
	<p>▶ Use only suitable evaluation instruments (see section 4.4).</p>

Measuring bridge

The measuring bridge of each of the 6 measurement channels is constructed as shown:

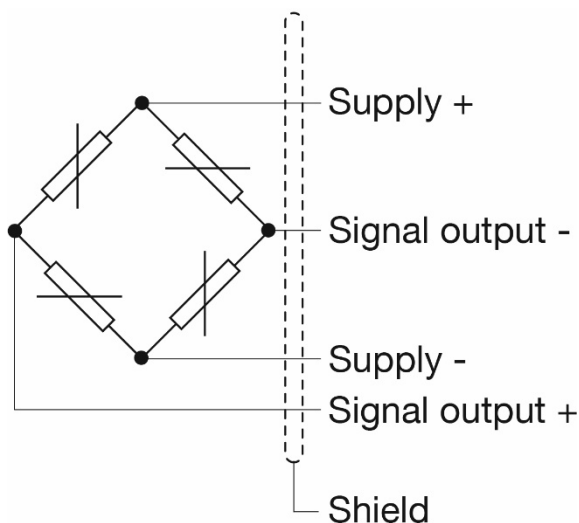

Figure 1: Measuring bridge

Connector pin assignment

The sensor is supplied with a matching mating connector. Optionally, you can also purchase matching open-ended cables or connectors to fit our amplifiers or evaluation electronics.

Note: For the optionally supplied display and calibration devices, please refer to the instruction manual of the device to be connected in order to ensure compatibility.

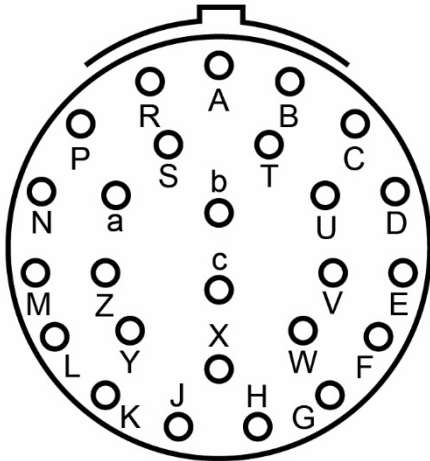



Figure 2: Connector pin assignment

- + Supply A (Fx) / E (Fy) / J (Fz) / N (Mx) / T (My) / X (Mz)
- Supply B (Fx) / F (Fy) / K (Fz) / P (Mx) / U (My) / Y X (Mz)
- + Signal C (Fx) / G (Fy) / L (Fz) / R (Mx) / V (My) / Z X (Mz)
- Signal D (Fx) / H (Fy) / M (Fz) / S (Mx) / W (My) / a X (Mz)

Note: For further details please refer to the data sheet (see section 15) or contact burster for technical advice (see <https://www.burster.de/en/load-cells>).

7 Using the sensor for the first time

	NOTICE
	<ul style="list-style-type: none">▶ Never put the sensor into service if it shows signs of damage incurred in transit.▶ Only ever use sensor under the conditions specified in this operation manual.

8 Operation

8.1 Measurement chain calibration

Each sensor is supplied with an individual test and calibration certificate. You can also download this test and calibration certificate at a later date by entering the serial number on the burster website (www.burster.com) (see section 15).

The downstream electronics must always be calibrated for the respective sensor. For details on calibration, see the operating instructions for the relevant downstream electronics.

8.2 Applying the force



This is how it works

- ▶ Apply force to the sensor via the four contact surfaces.

NOTICE	
	<ul style="list-style-type: none"> • The force application components must be ground flat (never convex) and lapped. • The material must be hardened, not just surface-hardened, and have 60 HRC hardness. • In the force application component there must not be any holes in the effective surfaces such as centering holes for lathes or grinding machines. • The specifications are valid exclusively with the provided force/torque apply surfaces.

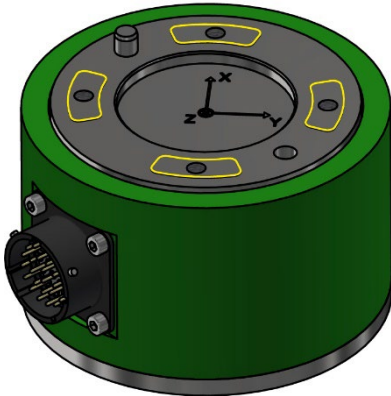



Figure 3: Force/torque application (contact surfaces marked yellow)

8.3 Monitor operation

8.3.1 Overload

You can recognize an overload from an increased output signal without any load (not built in your application without attachments). For information on the maximum load, see section 4.1.

Note: Check the sensor if the signal increases by more than approx. 5 %.

	NOTICE
	<ul style="list-style-type: none">▶ Do not apply sudden loads or accelerations to the sensor.▶ Dynamic loads above 70% of the rated force reduce the life of the sensor.

9 Maintenance and cleaning

9.1 Recalibration

The sensor should be recalibrated by the manufacturer after no more than 24 months.

Note: If the sensor is used in machines with high cycle rates, recalibration should be carried out sooner.

9.2 Cleaning

- ▶ Disconnect the sensor from the power supply and use a dry cloth to clean the sensor.

	NOTICE
	<ul style="list-style-type: none"> ▶ Do not immerse the sensor in water or hold it under running water. ▶ Do not use strong cleaning agents as these may damage the sensor.

10 Technical data

The technical data can be found on the data sheet (see section 15).

The latest version of the data sheet is available at:

<https://www.burster.de/en/load-cells/multi-component-sensors/p/detail/8565>

or simply use the following QR code:



10.1 Ambient conditions

Please note the following temperature ranges:

- Rated temperature range: +15 °C ... +70 °C
- Operating temperature range: -10 °C ... +80 °C

11 Accessories

You can find information about accessories on the data sheet (see section 15).

The latest version of the data sheet is available at:

https://www.burster.de/fileadmin/user_upload/redaktion/Documents/Products/Data-Sheets/Section_8/8565_EN.pdf

or simply use the following QR code:



12 Customer service

For repair inquiries, please call our customer service department on +49 7224 645-53.

Please have the serial number to hand. The serial number is the only way to clearly identify the technical version of the instrument so that we can provide help quickly. You will find the serial number on the type plate of the sensor.

13 Disposal



Instrument disposal

If your instrument is no longer usable, please comply with your legal obligations by disposing of the instrument described here in accordance with statutory regulations. You will then be helping to protect the environment!

14 Declaration of Conformity

The measurement solution.



EU-Konformitätserklärung (nach EN ISO/IEC 17050-1:2010) EU-Declaration of conformity (in accordance with EN ISO/IEC 17050-1:2010)

Name des Ausstellers: burster präzisionsmesstechnik gmbh & co kg
Issuer's name:

Anschrift des Ausstellers: Talstr. 1-5
Issuer's address: 76593 Gernsbach, Germany

Gegenstand der Erklärung: Kraftsensor
Object of the declaration: Load Cell

Modellnummer(n) (Typ): 84xx; 85xx
Model number / type: 84xx; 85xx

Diese Erklärung beinhaltet obengenannte Produkte mit allen Optionen
This declaration covers all options of the above product(s)

Das oben beschriebene Produkt ist konform mit den Anforderungen der folgenden Dokumente:
The object of the declaration described above is in conformity with the requirements of the following documents:

Dokument-Nr. <i>Documents No.</i>	Titel <i>Title</i>	Ausgabe <i>Edition</i>
2011/65/EU	Richtlinie zur Beschränkung der Verwendung bestimmter gefährlicher Stoffe in Elektro- und Elektronikgeräten <i>Directive on the restriction of the use of certain hazardous substances in electrical and electronic equipment</i>	2011
2014/30/EU	Richtlinie zur Harmonisierung der Rechtsvorschriften der Mitgliedsstaaten über die Elektromagnetische Verträglichkeit <i>Directive on the harmonization of the laws of the Member States relating to electromagnetic compatibility</i>	2014
EN 61326-1	Elektrische Mess-, Steuer-, Regel- und Laborgeräte – EMV-Anforderungen – Teil 1: Allgemeine Anforderungen <i>Electrical equipment for measurement, control and laboratory use – EMC requirements – Part 1: General requirements</i>	2013
EN 61326-2-3	Elektrische Mess-, Steuer-, Regel- und Laborgeräte – EMV-Anforderungen – Teil 2-3: Besondere Anforderungen <i>Electrical equipment for measurement, control and laboratory use – EMC requirements – Part 2-3: Particular requirements</i>	2006

Gernsbach
Ort / place

20.04.2016
Datum / date

i.V. Christian Karius
Quality Manager

Dieses Dokument ist entsprechend EN ISO/IEC 17050-1:2010 Abs. 6.1g ohne Unterschrift gültig
According EN ISO/IEC 17050 this document is valid without a signature.

burster präzisionsmesstechnik gmbh & co kg · Talstr. 1-5 DE-76593 Gernsbach (P.O.Box 1432 DE-76587 Gernsbach) · Tel. +49-7224-6450 · Fax 645-88
www.burster.com · info@burster.com · burster is ISO 9001:2008 certified

Geschäftsführer/Managing Director: Matthias Burster · Handelsregister/Trade Register: Gernsbach · Registergericht/Register Court: Mannheim HRA 530170
Kompl./Gen. Partn.: burster präzisionsmesstechnik Verwaltungs-GmbH · Handelsregister/Trade Register: Gernsbach · Registergericht/Register Court: Mannheim HRB 530130
UST-Identnr./VAT No. DE 144 005 098 · Steuernr./Tax Ident No. 39454/10503
Commerzbank AG Rastatt Kto./Acc. 06 307 073 00 BLZ/Bank code 662 800 53 · Volksbank Baden-Baden* Rastatt eG Kto./Acc. 302 082 00 BLZ/Bank code 662 900 00

15 Appendix

The following documents are supplied with the sensor:

Document	URL
Data sheet	https://www.burster.de/fileadmin/user_upload/redaktion/Documents/Products/Data-Sheets/Section_8/8565_EN.pdf
Test certificate	You can download the test certificate for your sensor via the following link, by entering its serial number: https://www.burster.de/en/service-calibration/download-your-test-and-calibration-certificates-here .